



Data Isolation Cards

2-Wire HDSL/56KBS Isolation Card
P30076

4-Wire HDSL/56KBS Isolation Card
P30050

Table of Contents

	Page
1.0 SCOPE	2
2.0 PRODUCT OVERVIEW	2
2.1 System Requirements	
2.2 Intended Uses	2
3.0 PRODUCT FEATURES	3
3.1 Transformer Isolation	3
4.0 INSTALLATION	3
P30050 Sealing Current or Powering Current Termination/Drainage	4
4 Wire Service with 2-Wire Cards-P30076	5
P30076 Sealing Current or Powering Current Termination/Drainage	5
5.0 PHYSICAL CHARACTERISTICS	6
6.0 SPECIFICATIONS	7
Table 1: Isolation Specifications	7
Table 2: External System Input Requirements	7
Table 3: Performance Specifications	7

1.0 SCOPE

This document describes the specifications, requirements and installation instructions for the P30076 (2-wire) and P30050 (4-wire) SNC Lyte Lynx® transformer-based, 56 kbs Data Isolation PC cards. It provides an understanding of the basic functions and features available with these products.

2.0 PRODUCT OVERVIEW

2.1 System Requirements

The P307076 and P30050 isolation cards are designed for installation in an SNC Lyte Lynx® or Teleline Isolator* Card Shelf. No powering is required for these passive devices.



P30076
2-Wire HDSL /56 kbs
Data Isolation Card



P30050
4-Wire HDSL/56 kbs
Data Isolation Card

2.2 Intended Uses

These data isolation models provide an isolated interface for 4-wire (P30050) or 2-wire (P30076) digital or analog data circuits. Types of digital circuits protected include rates of 2.4 kbps to 72 kbps as used in services such as Synchronet, Basic Rate ISDN and HDSL carrier frequencies. Types of analog circuits protected include rates of 100 Hz to 200 kHz as used in analog carrier, modems, SCADA, tone relay control and tone signaling.

* Teleline Isolator is a trademark of Positron Industries, Inc.

The primary function of the card is to provide an isolation from hazardous voltages while being “transparent” in the circuit. All signaling information within the specified frequency bandwidth will be unaffected. However, DC signaling is not supported. A secondary function is to provide connections for the loopback of DC simplex sealing current or repeater powering on the remote (Central Office) side. Normally there is no DC path for such current through the unit.

NOTE: On P30076 isolation cards, the loopback function will only work when using two P30076 2-wire cards for 4-wire service.

SNC Lyte Lynx® systems are intended for use at power substations and similar locations where high voltage isolation is required on the incoming copper telecom pairs to protect the network equipment from harm and to provide a personnel safety barrier against voltages within the limits of the isolator. This specifically includes protection from longitudinally induced voltage surges and Ground Potential Rise (GPR) that may occur during power system faults.

3.0 Product Features

3.1 Transformer Isolation

These Lyte Lynx® data isolation interface models are passive, magnetic-coupled devices. Primary to secondary isolation is rated at 65kV BIL. The center tap of the transmit and receive transformers are normally connected to one another (via the card shelf backplane when using two P30076 cards for 4-wire service) to provide sealing current or span line powering loopback at the remote side of the interface. However, a switch (SW1) is provided on the P30050 card to open or disconnect the center tap (CT) connection when necessary for use with certain HDSL terminal equipment.



WARNING: DO NOT connect center taps of CO/Remote and Station sides of transformers together. Doing so would disable the isolation interface and create a hazardous situation.

4.0 INSTALLATION



WARNING: To provide personnel isolation from local ground, stand on a thick rubber mat and use other adequate insulation devices (rubber gloves) when working on the isolation system.



CAUTION: The incoming telephone pairs should be contained in insulated conduit (PVC, etc.), or the pair should be jacketed with sufficient insulation to withstand a voltage rise from ground fault potential and from fault induction voltage.



CAUTION: Any metallic shielding on the incoming CO/Remote pairs must be isolated from substation grounds all the way from the network low voltage interface (300 volt peak GPR point per IEEE Standard 487) to the entry into the Card Shelf. The conductors must also be isolated.

The P30050 and P30076 Isolation Cards require an installed SNC Lyte Lynx® Card Shelf or Teleline Isolator* Card Shelf. The cards slide into any card shelf slot. With the card shelf installed and properly configured, slide the isolation card into any available slot and firmly plug it into the card shelf backplane receptacles. This may be done with or without power applied to the card shelf.

P30050 - Sealing Current or Powering Current Termination/Drainage

This card provides termination of simplexed sealing or span line powering current from 0-160mA of current on the **CO/Remote side**. The center taps of the individual transformers are each connected to a separate 2-electrode 350 volt gas tube with a high holdover voltage rating. (See Figures 1 and 2). The other side of the gas tubes should be connected to a 5kV spark gap bus and then to CO/Remote ground via the dedicated cable shield. The card accesses remote ground on the lower backplane when plugged into the lower backplane edge connector. The 25th pair, violet and slate conductors in the incoming CO/Remote cable bring remote ground to the card shelf backplane (terminals 35 and 36 on the SNC Lyte Lynx® shelf and TB1-1 and TB2-1 on the Teleline Isolator* shelf). (See Figure 1)

The center taps on the **station** side of the two transformers are connected for drainage purposes. The center taps access station ground when the PC isolation card plugs into the upper backplane edge connector.

NOTE: If **station** drainage is not required, jumper J1 may be clipped off.

Figure 1: P30050 4 Wire Card Schematic

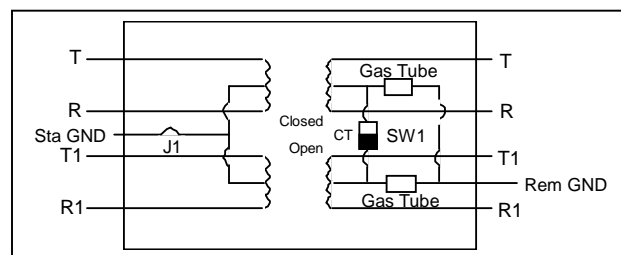

* Teleline Isolator is a trademark of Positron Industries, Inc.

The center tap of the transmit and receive transformers are normally connected to one another to provide sealing current or span line powering loop back at the remote side of the interface. A switch (SW1) is provided on the P30050 card to limit the current through a resistor. Open or disconnect the center tap (CT) connection while connected to a current limiting circuit when necessary for use with certain HDSL terminal equipment. The P30050 is shipped in the open condition since this is standard.

The Closed position allows the current to by-pass the resistor allowing up to 160 mA sealing current.

NOTE: 4-Wire Service with 2-Wire Cards (P30076)

If desired, two P30076 cards can be used to provide 4-wire service. For this configuration to work in the 12-slot SNC Lyte Lynx® Card Shelf, the two P30076 cards must be installed in slots 1 and 3, 5 and 7, or 9 and 11. The SW1 and SW2 switches on the lower (CO/Remote) backplane must be in the down or "Standard" position to connect the center taps of slots J1 to J3, and J9 to J11. In the Teleline Isolator* Card Shelf, the two cards must be installed in slots 1 and 2, 3 and 4, 5 and 6, or 7 and 8. The two cards are connected via the remote side backplane inside the card shelf. The 2-wire data isolation card P30076 has a two-position switch (J2) to allow 2-wire applications (such as ISDN) that have loop current present. Use the "Loop Current" position for this purpose. This allows DC loop sealing current to flow from tip to ring without saturating the transformer. The "dry" switch position is used when 2-wire isolation cards (P30076) are used for 4-wire service, and other 2-wire applications. (See Figure 2)

P30076 - Sealing Current or Powering Current Termination/Drainage

When using two P30076 2-Wire cards to provide 4-Wire service (see NOTE above) this card provides termination of simplex sealing or span line powering current from 0-160mA of current on the CO/Remote side. The center taps of the individual transformers on two P30076 cards may be tied together via the card shelf backplane.

Each transformer is connected to a 2-electrode 350 volt gas tube with a high holdover voltage rating. The other side of the gas tube should be connected to a 5kV spark gap bus, and then to CO/Remote ground via the dedicated cable shield. The card accesses remote ground on the lower backplane when plugged into the lower backplane edge connector. The 25th pair violet and slate conductors in the incoming CO/Remote cable bring remote ground to the card shelf backplane (terminals 35 and 36 on the SNC Lyte Lynx® shelf and TB1-1 and TB2-1 on the Teleline Isolator* card shelf). Jumper J2 can be clipped off of the remote side of the P30076 card if center tap connection is not required on remote side.

* Teleline Isolator is a trademark of Positron Industries, Inc.

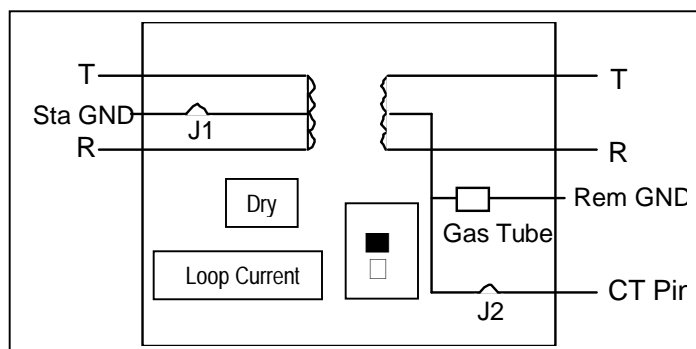

Figure 2: P30076 2-Wire Card Schematic

The center tap on the station side of the transformer is connected for drainage purposes. The center tap accesses station ground when the isolation card plugs into the upper backplane edge connector.

NOTE: If station drainage is not required, jumper J1 may be clipped off.

In reference to both the P30050 and P30076, the transformers have been tested and proven capable of handling 1000 + amps of drainage current for four milli-seconds. There are NO "sparkover identification" fuses or other extraneous "step potential piggy back" devices to blow that might cause the circuit to shut down and compromise "Class A" or "Class B" service. The isolation card's purpose is to protect the customer's station equipment - they are sufficiently robust to do the job without gimmicks to "protect the protector."



CAUTION: All station terminal apparatus should be on the same ground grid when the station ground is connected in the Isolation Card Shelf.

5.0 PHYSICAL CHARACTERISTICS

5.1 Mechanical Configuration

Mechanical stability is provided by two separate backplanes in the card shelf, one on the substation side and one on the remote side. The Isolation Cards are two-sided printed circuit boards manufactured in accordance with the appropriate PCB standards.

6.0 SPECIFICATIONS

TABLE 1: ISOLATION SPECIFICATIONS

LONGITUDINAL SURGE (1.2 x 50 micro-sec)	65 kV PEAK
CONTINUOUS RATING AC	20 kVrms
CONTINUOUS RATING DC	58 kVdc

TABLE 2: EXTERNAL SYSTEM INPUT REQUIREMENTS

INPUT SPECIFICATION	REQUIREMENT
SIGNAL SOURCE & TERMINATION IMPEDANCES	100, 124, 135, 600 or 900 Ohm
LOOP ATTENUATION (Sum of remote side and station side loops)	34dB Maximum
SIGNAL LEVEL 1000 - 1200Hz @ 600 Ohms 32kHz @ 135 Ohms	+10dBm Maximum +19dBm Maximum

TABLE 3: PERFORMANCE SPECIFICATIONS

PARAMETER	SPECIFICATIONS
LONGITUDINAL BALANCE	>70Db
RETURN LOSS 600 Ohm Source Impedance 1200 - 4000 Hz	>18dB
RETURN LOSS 135 Ohm Source Impedance 2.4 kHz 32 kHz	>14dB >18dB
MESSAGE CIRCUIT NOISE (Idle Channel Noise) 1.2 k - 4000 Hz @ 600 Ohms	<0 dBmC
PHASE JITTER	<0.5 degree <1p p-p
SIGNAL TO NOISE RATIO	>50Db
INSERTION LOSS Relative to 1.2 kHz @ 600 Ohms Relative to 32 kHz @ 135 Ohms	<0.3 dBm <0.1 dBm
FREQUENCY RESPONSE Relative to 1.2 kHz @ 600 Ohms; -3.0 dB Relative to 32 kHz @ 135 Ohms; -3.0 dB	100 Hz -200 kHz 1.4 - 325 kHz
CROSSTALK (to adjacent channel)	< -65dB
SINGLE FREQUENCY DISTORTION	<2% THD
TEMPERATURE RANGE	-40 to +100° C (-40 to 212° F)
HUMIDITY RANGE	5 TO 99% Relative Humidity
DRAINAGE CAPACITY - Minimum	0.5 Amps continuous (400 A2S Surge Drainage Rating)

SNC 56kbs/HDSL Transformers

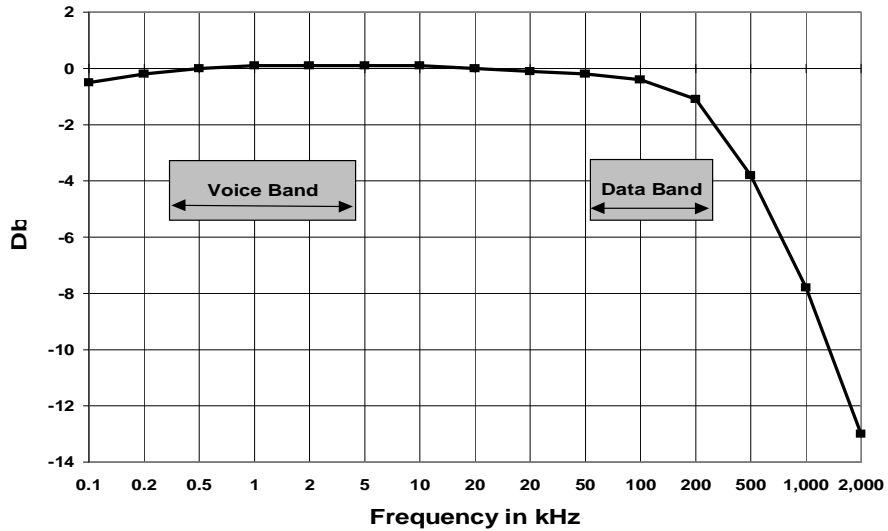

For further information or for technical support - call 800-558-3325
or visit www.sncmfg.com



SNC Manufacturing Co., Inc.
101 West Waukau Ave., Oshkosh, WI 54902-7299
800-558-3325 or 920-231-7370 FAX 920-231-1090
E-mail: telecom@sncmfg.com
Website: www.sncmfg.com