



Data Isolation Cards

2-Wire HDSL2/HDSL/56KBS Isolation Card
P30115

4-Wire HDSL2/HDSL/56KBS Isolation Card
P30117

Table of Contents

| | Page |
|---|------|
| 1.0 SCOPE | 2 |
| 2.0 PRODUCT OVERVIEW | 2 |
| 2.1 System Requirements | |
| 2.2 Intended Uses | 2 |
| 3.0 PRODUCT FEATURES | 3 |
| 3.1 Transformer Isolation | 3 |
| 4.0 INSTALLATION | 3 |
| P30117 Sealing Current or Powering Current | 4 |
| 4 Wire Service with 2-Wire Cards | 5 |
| P30115 Sealing Current or Powering Current | 5 |
| 5.0 PHYSICAL CHARACTERISTICS | 6 |
| 6.0 SPECIFICATIONS | 7 |
| Table 1: Isolation Specifications | 7 |
| Table 2: External System Input Requirements | 7 |
| Table 3: Performance Specifications | 7 |

1.0 SCOPE

This document describes the specifications, requirements and installation instructions for the P30115 (2-wire) and P30117 (4-wire) SNC Lyte Lynx® transformer-based, 56 kbs Data Isolation PC cards. It provides an understanding of the basic functions and features available with these products.

2.0 PRODUCT OVERVIEW

2.1 System Requirements

The P30115 and P30117 isolation cards are designed for installation in an SNC Lyte Lynx® or Teleline Isolator* Card Shelf. No powering is required for these passive devices.



P30115
2-Wire HDSL2 /56kbs
Data Isolation Card



P30117
4-Wire HDSL2/56kbs
Data Isolation Card

2.2 Intended Uses

These data isolation models provide an isolated interface for 4-wire (P30117) or 2-wire (P30115) digital or analog data circuits. Types of digital circuits protected include rates of 2.4 kbps to 72 kbps as used in services such as Synchronet, Basic Rate ISDN and HDSL carrier frequencies. Types of analog circuits protected include rates of 100 Hz to 200 kHz as used in analog carrier, modems, SCADA, tone relay control and tone signaling.

* Teleline Isolator is a trademark of Positron Industries, Inc.

The primary function of the card is to provide an isolation from hazardous voltages while being “transparent” in the circuit. All signaling information within the specified frequency bandwidth will be unaffected. However, DC signaling is not supported. A secondary function is to provide connections for the loopback of DC simplex sealing current or repeater powering on the remote (Central Office) side.

SNC Lyte Lynx® systems are intended for use at power substations and similar locations where high voltage isolation is required on the incoming copper telecom pairs to protect the network equipment from harm and to provide a personnel safety barrier against voltages within the limits of the isolator. This specifically includes protection from longitudinally induced voltage surges and Ground Potential Rise (GPR) that may occur during power system faults.

3.0 PRODUCT FEATURES

3.1 Transformer Isolation

These Lyte Lynx® data isolation interface models are passive, magnetic-coupled devices. Primary to secondary isolation is rated at 65kV BIL. A switch (SW1 or SW2) is provided on each circuit of the card to allow dry or loop current connection when necessary for use with certain HDSL terminal equipment.



WARNING: DO NOT connect center taps of CO/Remote and Station sides of transformers together. Doing so would disable the isolation interface and create a hazardous situation.

4.0 INSTALLATION



WARNING: To provide personnel isolation from local ground, stand on a thick rubber mat and use other adequate insulation devices (rubber gloves) when working on the isolation system.



CAUTION: The incoming telephone pairs should be contained in insulated conduit (PVC, etc.), or the pair should be jacketed with sufficient insulation to withstand a voltage rise from ground fault potential and from fault induction voltage.



CAUTION: Any metallic shielding on the incoming CO/Remote pairs must be isolated from substation grounds all the way from the network low voltage interface (300 volt peak GPR point per IEEE Standard 487) to the entry into the Card Shelf. The conductors must also be isolated.

The P30117 and P30115 Isolation Cards require an installed SNC Lyte Lynx® Card Shelf or Teleline Isolator* Card Shelf. The cards slide into any card shelf slot. With the card shelf installed and properly configured, slide the isolation card into any available slot and firmly plug it into the card shelf backplane receptacles. This may be done with or without power applied to the card shelf.

Sealing Current or Powering Current - P30117

This card provides termination of simplex sealing or span line powering current from 0-160mA of current on the **CO/Remote side**. The center taps of the individual transformers are each connected to a separate 2-electrode 350 volt gas tube with a high holdover voltage rating. The other side of the gas tubes should be connected to a 5kV spark gap bus and then to CO/Remote ground via the dedicated cable shield. The card accesses remote ground on the lower backplane when plugged into the lower backplane edge connector. The 25th pair, violet and slate conductors in the incoming CO/Remote cable bring remote ground to the card shelf backplane (terminals 35 and 36 on the SNC Lyte Lynx® shelf and TB1-1 and TB2-1 on the Teleline Isolator* shelf). (See Figure 1.)

The center taps on the **station** side of the two transformers are connected for drainage purposes. The center taps access station ground when the PC isolation card plugs into the upper backplane edge connector.

NOTE: If **station** drainage is not required, jumper J1 may be clipped off.

Figure 2: P30117 4-Wire Card Schematic

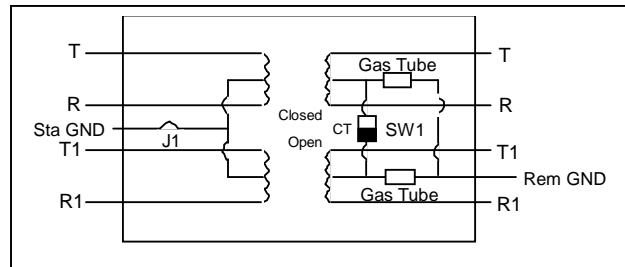

The transformers have been tested and proven capable of handling 1000+ amps of drainage current for four milli-seconds. There are NO "sparkover identification" fuses or other extraneous "step potential piggy back" devices to blow that might cause the circuit to shut down and compromise "Class A" or "Class B" service. The isolation card's purpose is to protect the customer's station equipment - they are sufficiently robust to do the job without gimmicks to "protect the protector."

* Teleline Isolator is a trademark of Positron Industries, Inc.

NOTE: 4-Wire Service with 2-Wire Cards

If desired, a P30116 card can be used to provide 4-wire service. The 2-wire data isolation card (P30115) has a two-position switch (J2) to allow 2-wire applications (such as ISDN) which have loop current present. Use the "Loop Current" position for this purpose. This allows DC loop sealing current to flow from tip to ring without saturating the transformer. The "dry" switch position is used when 2-wire isolation cards (P30115) are used for other 2-wire applications.

Sealing Current or Powering Current - P30115

When using two P30115 2-Wire cards to provide service (see NOTE above) this card provides termination of simplexed sealing or span line powering current from 0-160mA of current on the CO/Remote side.

Each transformer is connected to a 2-electrode 350 volt gas tube with a high holdover voltage rating. (See Figure 2.) The other side of the gas tube should be connected to a 5kV spark gap bus and then to CO/Remote ground via the dedicated cable shield. The card accesses remote ground on the lower backplane when plugged into the lower backplane edge connector. The 25th pair violet and slate conductors in the incoming CO/Remote cable bring remote ground to the card shelf backplane (terminals 35 and 36 on the SNC Lyte Lynx® shelf and TB1-1 and TB2-1 on the Teleline Isolator* card shelf). Jumper J2 can be clipped off of the remote side of the P30115 card if center tap connection is not required on remote side.

The center tap on the **station** side of the transformer is connected for drainage purposes. The center tap accesses station ground when the isolation card plugs into the upper backplane edge connector.

NOTE: If **station** drainage is not required, jumper J1 may be clipped off.

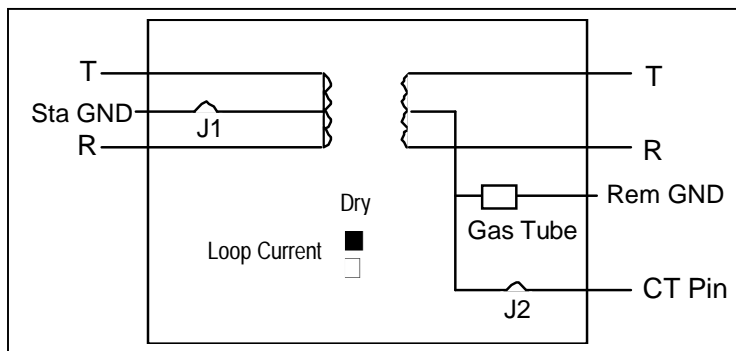

Figure 2: P30115 2-Wire Card Schematic

* Teleline Isolator is a trademark of Positron Industries, Inc.

The transformer has been tested and proven capable of handling 1000 + amps of drainage current for four milli-seconds. There are NO "sparkover identification" fuses or other extraneous "step potential piggy back" devices to blow that might cause the circuit to shut down and compromise "Class A" or "Class B" service. The isolation card's purpose is to protect the customer's station equipment - they are sufficiently robust to do the job without gimmicks to "protect the protector."



CAUTION: All station terminal apparatus should be on the same ground grid when the station ground is connected in the Isolation Card Shelf.

5.0 PHYSICAL CHARACTERISTICS

5.1 Mechanical Configuration

Mechanical stability is provided by two separate backplanes in the card shelf - one on the substation side and one on the remote side. The Isolation Cards are two-sided printed circuit boards manufactured in accordance with the appropriate PCB standards.

Figure 4: Physical Characteristics

| | Height | Depth | Width |
|----------------------|--------------------------------|--------------------------------|-----------------------------------|
| P30117/P30115 | 12" (30.5 cm) | 1.5" (3.8 cm) | 7.437" (18.9 cm) |

6.0 SPECIFICATIONS

TABLE 1: ISOLATION SPECIFICATIONS

| | |
|---|------------|
| LONGITUDINAL SURGE (1.2 x 50 micro-sec) | 65 kV PEAK |
| CONTINUOUS RATING AC | 20 kVrms |
| CONTINUOUS RATING DC | 58 kVdc |

TABLE 2: EXTERNAL SYSTEM INPUT REQUIREMENTS

| INPUT SPECIFICATION | REQUIREMENT |
|---|----------------------------------|
| SIGNAL SOURCE & TERMINATION IMPEDANCES | 100, 124, 135, 600 or 900 Ohm |
| LOOP ATTENUATION (Sum of remote side and station side loops) | 34dB Maximum |
| SIGNAL LEVEL 1000 - 1200Hz @ 600 Ohms 32kHz @ 135 Ohms | +10dBm Maximum +19dBm Maximum |
| | |
| | |

TABLE 3: PERFORMANCE SPECIFICATIONS

| PARAMETER | SPECIFICATIONS |
|---|---|
| LONGITUDINAL BALANCE (1.2 - 300 kHz) | >70Db |
| RETURN LOSS 600 Ohm Source Impedance 1200 - 4000 Hz | >18dB |
| RETURN LOSS 135 Ohm Source Impedance 2.4 kHz 32 kHz | >14dB >18dB |
| MESSAGE CIRCUIT NOISE (Idle Channel Noise) 1.2 k - 4000 Hz @ 600 Ohms | <0 dBmC |
| PHASE JITTER | <0.5 degree <1p p-p |
| SIGNAL TO NOISE RATIO | >50Db |
| INSERTION LOSS Relative to 1.2 kHz @ 600 Ohms Relative to 32 kHz @ 135 Ohms | <0.3 dBm <0.1 dBm |
| FREQUENCY RESPONSE Relative to 1.2 kHz @ 600 Ohms; -3.0 dB Relative to 32 kHz @ 135 Ohms; -3.0 dB | 100 Hz -200 kHz 1.4 - 325 kHz |
| CROSSTALK (to adjacent channel) | < -65dB |
| SINGLE FREQUENCY DISTORTION | <2% THD |
| TEMPERATURE RANGE | -40 to +100° C (-40 to 212° F) |
| HUMIDITY RANGE | 5 TO 99% Relative Humidity |
| DRAINAGE CAPACITY - Minimum | 0.5 Amps continuous (400 A2S Surge Drainage Rating) |
| | |

SNC 56kbs/HDSL Transformers

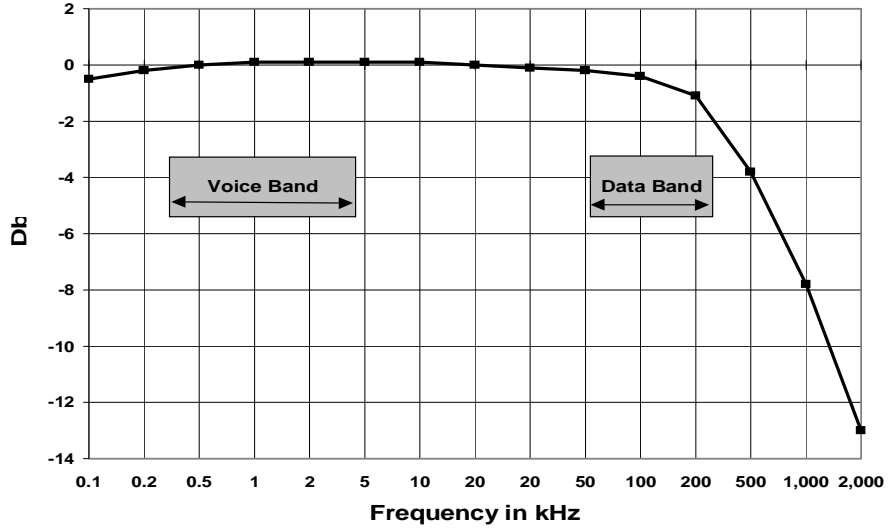

For further information or for technical support - call 800-558-3325
or visit www.sncmfg.com



SNC Manufacturing Co., Inc.
101 West Waukau Ave., Oshkosh, WI 54902-7299
800-558-3325 or 920-231-7370 FAX 920-231-1090
E-mail: telecom@sncmfg.com
Website: www.sncmfg.com